



Melt Flow Index Deluxe



Model No. MFI-DX

Melt Flow Index Tester is a consistent tool useful for checking the flow properties of molten plastics/resins. PRESTO Melt Flow Index Tester is manufactured under various Test Standards ASTM D 1238-1992, IS 2267-1972, IS 2530-1963, IS 10810-1984.

- Microprocessor based PID controller
- Automatic sample cutting
- Digital Preset Timer for accuracy and repeatability
- Die Steel barrel for uniform and consistent heating of barrel/test cylinder.

Melt Flow Index is defined as the rate of flow of extrudate of molten resins through a jet of a specific length and diameter under prescribed conditions of temperature, load and piston position inside a heated metallic barrel. Melt flow Index of thermoplastic material is expressed in terms of grams per 10 min of extrudate of molten resins that flow through the heated cylindrical barrel.

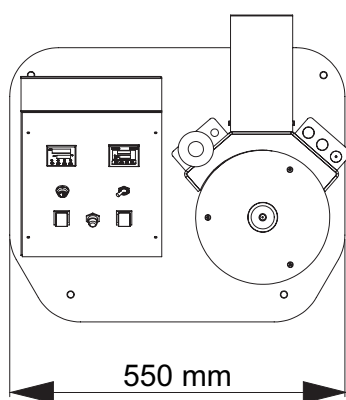

Top View

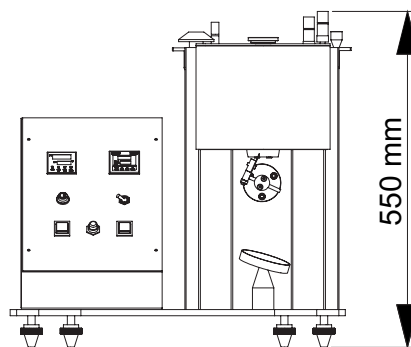

Front View

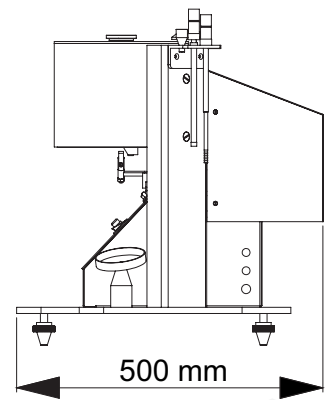

Side View



Presto Stantest Pvt. Ltd.

I-42, DLF Industrial Area Phase-1, Delhi Mathura Road, Faridabad 121003, Haryana, India
P : 9210 903 903, +91 129 4272727, 93111 24302 E : info@prestogroup.com

- Faridabad • Sonipat • Kolkata • Mumbai • Pune • Ahmedabad
- Chennai • Bangalore • Hyderabad

www.prestogroup.com



Key Specifications:

Display	Digital 7 Segment
Temperature Range	Ambient to 400°C
Accuracy	± 1°C
Least Count/Resolution	0.1°C
Power	220V , Single phase, 50 Hz
Sample Cutting	Automatic Motorized
Temperature Control	PID Temperature Controller
Timer	Digital Preset upto 999 seconds
Inner Diameter of heating barrel(cylinder)	9.550mm ± 0.007mm
Inner Diameter of Die	2.095mm ± 0.005mm
Diameter of piston head	9.474mm ± 0.007mm
Material of Heating Barrel(Cylinder)	Die Steel
Sample Cutting Motor	Torque 7Kg/cm ² , 60RPM

Standard Accessories :-

- Orifice Inbuilt - 1
- Funnel - 1
- Mirror with stand - 1
- Piston - 1
- Deadweight - 4
- Orifice cleaner - 1
- Barrel cleaner - 1
- Material Charger - 1
- Plumb line - 1
- Spool - 1

Highlights:

No. of Dead Weights	4 (1.2 kg, 2.16 kg, 3.8 kg, 5 kg)
Material	Mild Steel
Finish	Powder coated Havel Gray & Blue combination finish and bright chrome / zinc plating for corrosion resistant finish
Dimensions	550 x 550 x 500 mm

* The Melt Flow Index in grams per 10min. of the test specimen can be calculated.

Optional :

- Melt Flow Index Next Generation model with touchscreen facility also available.
- Other Specific Deadweight also available on request
- Weighing scale (200 gram) also available on request.

Thank you customers for choosing us as your partners in growth !



*All the above logos are the sole property of their respective owners and are used purely for depiction purposes only.

OUR OTHER PRODUCTS :-



Box Compression Tester

Scuff Resistance Tester

Tensile Tester Digital

Spectrocolorimeter

Cobb Sizing Tester

Digital GSM Balance

