



## Izod / Charpy Impact Tester Computerised



Model No. : IZC -222 (C)

**IZOD/Charpy Impact Tester** is a consistent tool to measure the impact resistance of materials under sudden falling force or impact. PRESTO IZOD/Charpy Impact Tester is manufactured under various Test Standards ASTM D256 - 10, ASTM D618 - 13, ASTM D883 - 12, ASTM D1204 - 14, ASTM D1248 - 12, ASTM E691-14.

- Microprocessor based display for accurate test results
- Display for impact/absorbed energy and angle of test specimen
- Separate fixtures for Izod and Charpy test.
- Highly accurate test results under impact forces.
- Strong gripping fixtures for Izod / Charpy tests.
- Electromagnetic Pendulum release mechanism
- Graph test report is Energy Vs Angle
- Email facility of report
- Can be calculate multiple test unit J/m, Kg.cm/cm, Kg.m/m
- USB port for PC keypad interface
- Alphanumerical keypad for data entry
- Inbuilt calibration facility
- High speed ADC interface

### Test Report

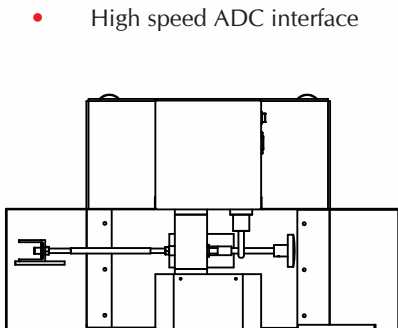
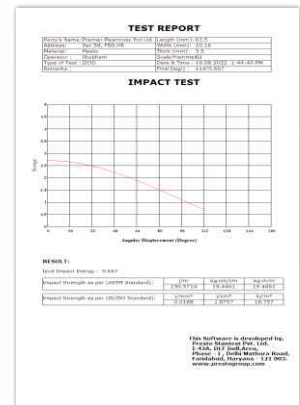

Top View

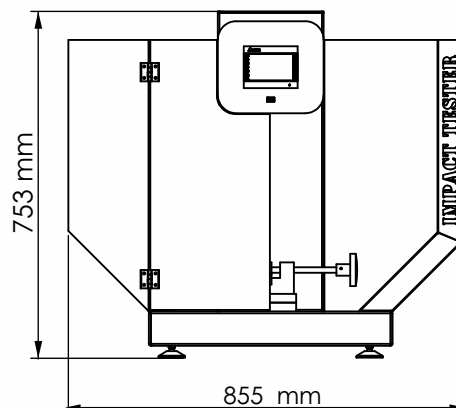

Front View

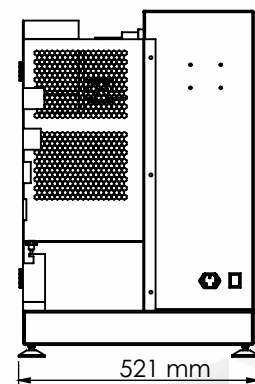

Side View



# Presto Stantest Pvt. Ltd.

I-42, DLF Industrial Area Phase-1, Delhi Mathura Road, Faridabad 121003, Haryana, India  
P : 9210 903 903, +91 129 4272727, 93111 24302 E : info@prestogroup.com

- Faridabad • Sonipat • Kolkata • Mumbai • Pune • Ahmedabad
- Chennai • Bangalore • Hyderabad

[www.prestogroup.com](http://www.prestogroup.com)



Izod/Charpy Impact Tester reveals the impact strength in terms of J/m. This tester is used to designed to check the impact strength of plastics.

## Key Specifications:

Capacity	Upto 21.68 Joules
Range of Scales	2.71 J, 5.42 J, 10.84 J, 21.68 J
Display	LED (Digital) 7 Segment
Accuracy	± 2% at full range
Resolution	R1-0.02, R2-0.05, R3-0.1, R4-0.2 J respectively
Power	220V , Single phase, 50 Hz
Release angle of pendulum	150°
Radius of Izod Hammer	0.79 ± 0.12 mm
Radius of Charpy Hammer	3.17 ± 0.12 mm

## Highlights:

Computer Connectivity	Yes with USB port
Pendulum Release Mechanism	Electromagnetic
Material	Mild Steel
Finish	Powder coated Havel Gray & Blue combination finish and bright chrome / zinc plating for corrosion resistant finish
Dimensions	855 x 521 x 753 mm

The Izod/Charpy Impact test is significant in testing and evaluating the impact resistance of various plastic products. The test is used to determine the energy that is required to break a standard test specimen using the pendulum method. This highly reliable instrument is a must for all plastic testing laboratories and quality control departments.

## Optional Accessory :

- Motorized Notch Cutter
- Izod Impact Tester Touch screen model also available.

\* PC system is not a part of supply.

Thank you customers for choosing us as your partners in growth !



\*All the above logos are the sole property of their respective owners and are used purely for depiction purposes only.

## OUR OTHER PRODUCTS :-

Top Load Tester Computerised	Wall Thickness Gauge	Transparency Tester	Eccentricity Tester	Moisture Analyzer MB 45	Preform Neck Cutter

